

STANDARD ROUND SIZES

PIPE CHAMBER SIZE (ID)	MAX SECTION HEIGHT	WALL	MAX PIPE SIZE	MAX WEIGHT
48" DIA - SEE DWG #STM-MH-48				
60" DIA	60"	6"	36"	9,212# (1,300#/VF)
72" DIA	72"	7"	48"	15,240# (1,800#/VF)
96" DIA	96"	9"	60"	36,000# (3,093#/VF)

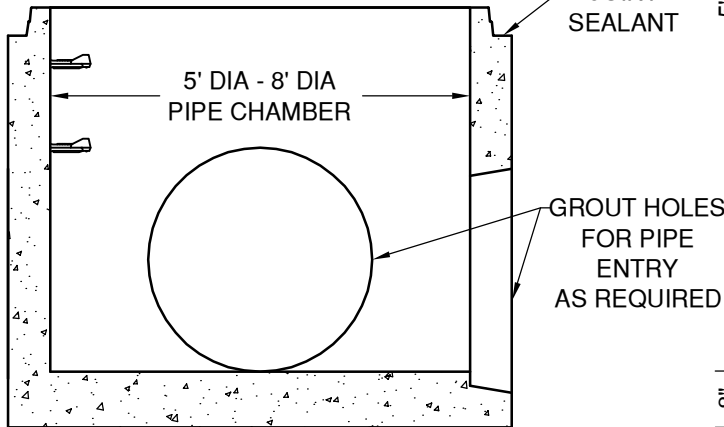

REDUCER SECTION VIEW

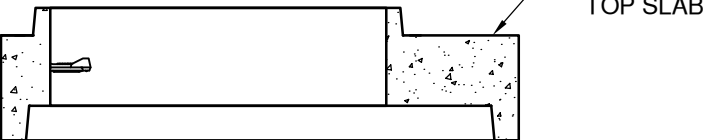
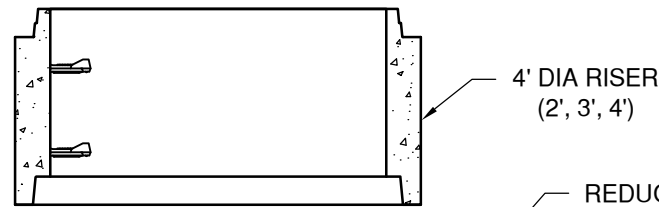
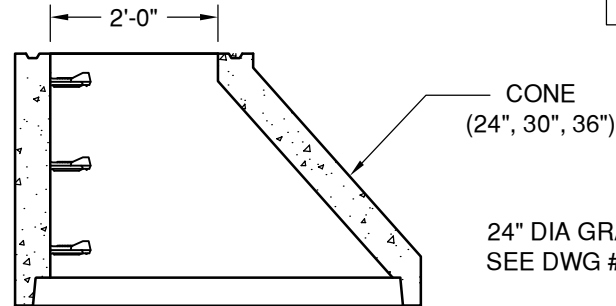
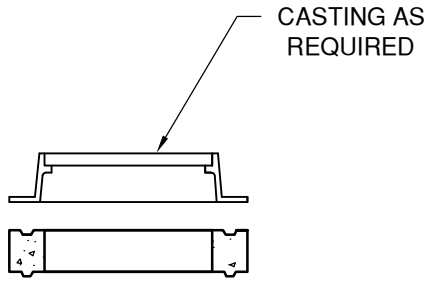
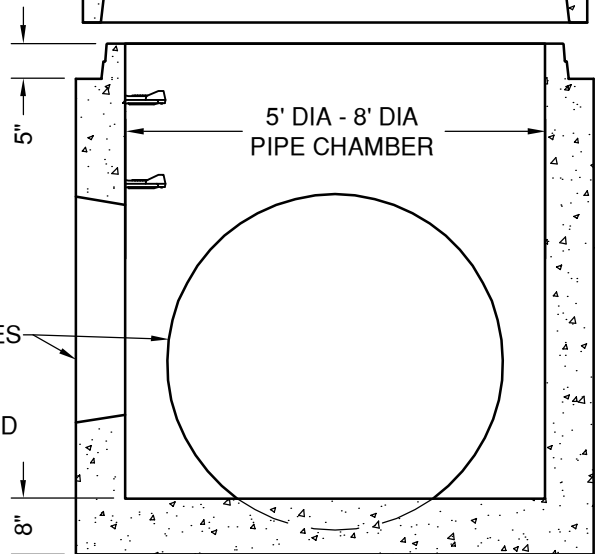
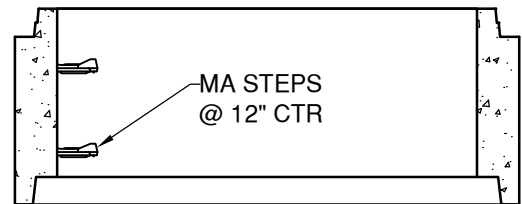
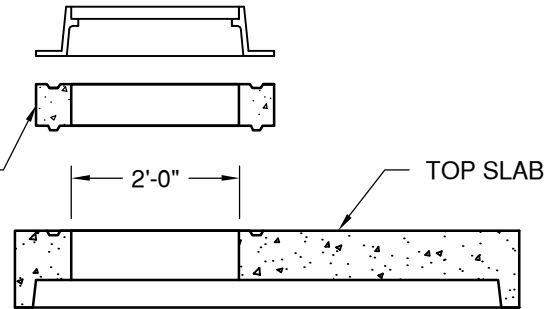

STANDARD SECTION VIEW



"NPCA" CERTIFIED PLANT
16700 SIMA GRAY RD, HENRYVILLE, IN 47126
Phone: (812) 246-6258 Fax: (812) 294-4862

SPECIFICATIONS

CONCRETE: 4500 PSI @ 28 DAYS
REINFORCEMENT: ASTM A-615, GR 60
DESIGN LOAD: AASHTO HS-20
DESIGN SPECIFICATION: ASTM C-478

WEIGHT: See Chart

STORM MANHOLE 5' DIA - 8' DIA

DATE: 12-20-16

DWG #STM-MH-5-8