

PLAN VIEW

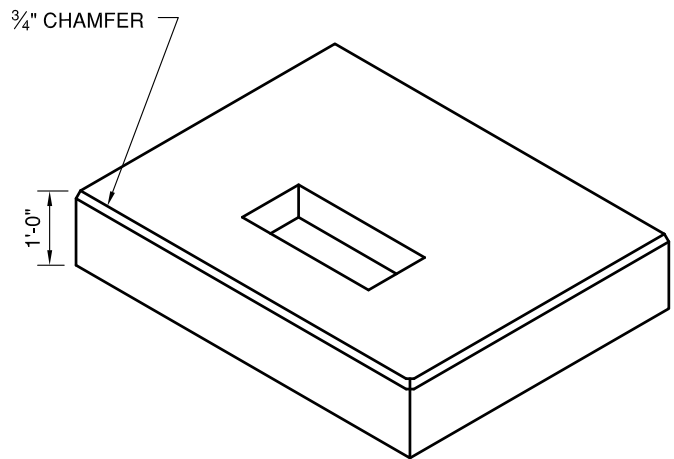

ISOMETRIC VIEW

STANDARD TRANSFORMER SIZES				
KVA	W	Y	U	WEIGHT
75-150	8'-5"	5'	5'-1"	5,000#
225-300	8'-6"	5'-8"	5'-4"	5,829#
500	8'-6"	6'	5'-4"	6,250#
750	8'-6"	6'-6"	5'-4"	6,888#
1000	8'-6"	7'	5'-4"	7,525#
1500	8'-6"	8'-10"	5'-4"	9,858#
2000	9'-9"	9'	5'-8"	11,675#
2500	10'-1"	9'	6'-1"	12,011#



"NPCA" CERTIFIED PLANT
 16700 SIMA GRAY RD, HENRYVILLE, IN 47126
 Phone: (812) 246-6258 Fax: (812) 294-4862

SPECIFICATIONS

CONCRETE: 4500 PSI @ 28 DAYS
 REINFORCEMENT: ASTM A-615, GR 60
 DESIGN LOAD: AASHTO HS-20

WEIGHT: See Chart

**TRANSFORMER PAD
 NOLIN RECC
 3 PHASE PAD**

DATE: 3-25-19

DWG #EL-TP-NOLIN