

**PLAN VIEW**

Pipe Size	Hole Size	Weight
21"	31"	7,115#
24"	35"	6,985#

Grate Size	Qty	Weight
2'-0" x 3'-0"	2	91# EA.
3'-0" x 3'-0"	1	118#

PIPE SIZE      HOLE SIZE

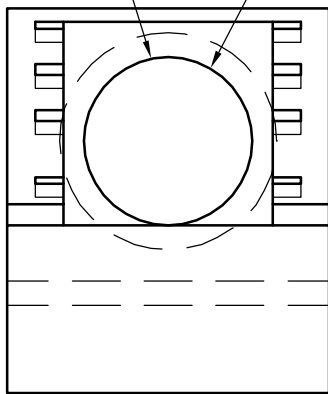

**FRONT VIEW**

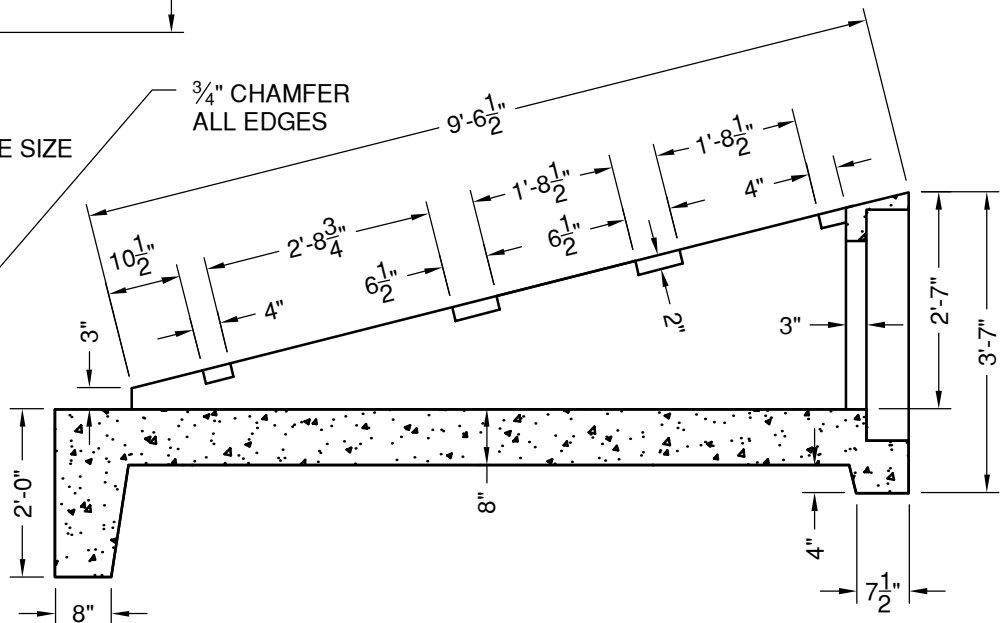

**SECTION VIEW**



"NPCA" CERTIFIED PLANT  
16700 SIMA GRAY RD, HENRYVILLE, IN 47126  
Phone: (812) 246-6258 Fax: (812) 294-4862

**SPECIFICATIONS**

CONCRETE: 4500 PSI @ 28 DAYS  
REINFORCEMENT: ASTM A-615, GR 60  
DESIGN SPECIFICATION: KYTC RDB-100-04  
GRATE DESIGN SPECIFICATION: KYTC RDB-101-04

WEIGHT: See Chart

**SLOPED BOX OUTLET  
TYPE 1  
21" - 24" PIPE**

DATE: 03-26-18

DWG #HW-SBO-24