

"TRAFFIC SIGNAL"
FRAME & COVER
320 LBS

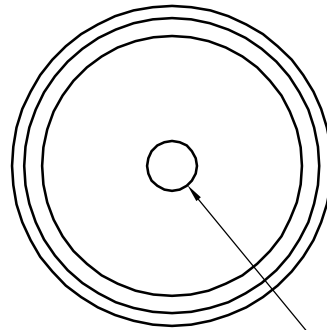

5" DIA HOLE

PLAN VIEW - CASTING

PLAN VIEW - HANDHOLE

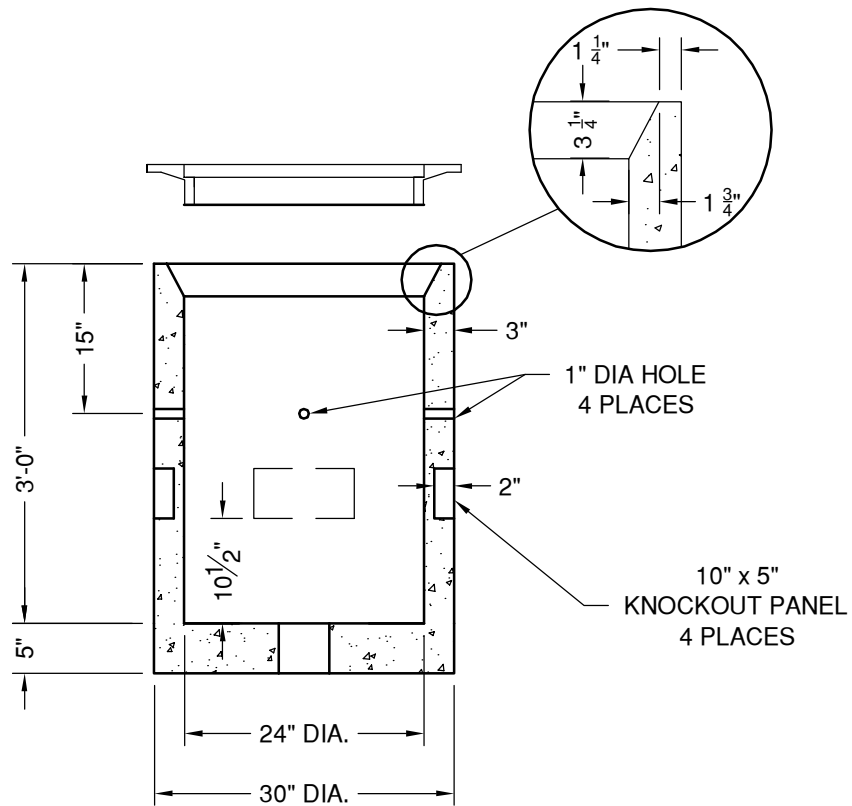

SECTION VIEW



"NPCA" CERTIFIED PLANT
16700 SIMA GRAY RD, HENRYVILLE, IN 47126
Phone: (812) 246-6258 Fax: (812) 294-4862

SPECIFICATIONS

CONCRETE: 4500 PSI @ 28 DAYS
REINFORCEMENT: ASTM A-615, GR 60
REF: INDOT STD DWG# E 805-SGCF-04

WEIGHT: 950#

INDOT HANDHOLE

DATE: 8-5-16

DWG #IN-HH